

**TORQUEMETER  
INSTALLATION, OPERATION, AND TROUBLESHOOTING GUIDE**

*with*

**WARRANTY STATEMENT**

**REVISION D, VERSION 1.1 FOR MCRT® 79000V SERIES DUAL RANGE MODELS**

**PATENT NOTICE:** Himmelstein torque measurement products are manufactured under one or more of the following U.S. Patents: RE26,501; 3,441,886; 3,531,748; 3,531,749; 3,717,029; 3,800,591; 3,961,526; 4,412,198; 4,555,956; 4,563,905; 4,616,512; 4,651,573; 4,790,175.

*Model Number:* .....

*Customer:* .....

*Serial Number:* .....

*Factory Reference Number:* .....

*Torque Range (lbf-in): Low Range:* ..... *High Range:* .....

*Overload Capacity (lbf-in):* .....

*Maximum RPM:* .....

*Performance Code:* .....

*Speed Pickup Code :* .....

*Foot Mount:*                     *Yes*                     *No*

*Noise Hardened (Option G):*                     *Yes*                     *No*

*Special Features:* .....

.....

.....

***S. HIMMELSTEIN AND COMPANY***

2490 Pembroke Avenue, Hoffman Estates, Illinois 60169, USA. Tel:847/843-3300 Fax:847:843-8488

# TABLE OF CONTENTS

	Page		Page
<b>i. Introduction</b> .....	3	<b>D. Troubleshooting</b>	
<b>ii. DC Operated Torquemeter Specification</b> .....	3	D.1 Scope .....	12
<b>A. Mechanical Installation</b>		D.2 Preliminary Inspection .....	12
A.1 Applicability .....	3	D.2.1 DC Operated Torquemeter .....	12
A.2 Coupling Selection .....	4	D.2.2 Cabling .....	12
A.3 Coupling Installation .....	4	D.2.3 Readout Instrument .....	12
A.4 End-to-End Orientation .....	5	D.3 Torque Subsystem Problems .....	12
A.4.1 Effect On Signal Polarity .....	5	D.3.1 No Output When Torque Is Present .....	12
A.4.2 Effect On Thrust Capacity .....	5	D.3.2 Constant Or Full Scale Output .....	12
A.5 Vertical Installations and Belt/Chain Drives .....	5	D.3.3 Apparent Zero Drift .....	13
<b>B. Electrical Installation</b>		D.3.4 Signal Instability .....	13
B.1 Applicability .....	5	D.3.5 System Will Not Zero .....	13
B.2 Torque Signal .....	5	D.4 Speed Subsystem Problems .....	13
B.2.1 Electrical Connections .....	5	D.4.1 No Output When Shaft Is Rotating .....	13
B.2.2 Output Bandwidth Selection .....	6	D.4.2 Erratic Output At Constant Speed .....	14
B.2.3 Zero and Span Adjustment .....	6	D.4.3 Output When Shaft Is Stationary .....	14
B.2.4 Calibration Intervals .....	6	D.4.4 Pickup Adjustment/Replacement .....	14
B.3 Speed Signal .....	7	D.4.4.1 Code A Passive Speed Pickup .....	15
B.3.1 Code A Passive Pickup Connections .....	7	D.4.4.2 Code Z Zero Velocity Pickup .....	15
B.3.2 Code A Passive Speed Cabling .....	7	D.4.4.3 Replacement Part Numbers .....	15
B.3.3 Code Z Zero Velocity Pickup Pinout .....	7	<b>E. Summary of References</b>	
B.3.4 Code Z Zero Velocity Pickup Cabling .....	8	E.1 Torquemeter Loads And Specifications .....	16
<b>C. Operating &amp; Safety Considerations</b>		E.2 Coupling Selection And Torquemeter Installation .....	16
C.1 Applicability .....	8	E.3 High Speed Operation .....	16
C.2 Allowable Torque Loads .....	8	E.4 Minimizing The Effects Of Torsionals .....	16
C.2.1 Overload Considerations .....	8	E.5 Selecting the Right Torquemeter .....	16
C.2.2 Fatigue Considerations .....	9		
C.2.3 Starting High Inertias With Electric Motors .....	9	<b>Appendices</b>	
C.3 Allowable Bearing Loads .....	9	I Foot Mounted Versus Floating Shaft Installations .....	16
C.4 Allowable Extraneous Loads .....	10	II Vertical Installations .....	17
C.4.1 Allowable Bending Loads .....	10	III Fatigue Considerations .....	17
C.4.2 Allowable Thrust Loads .....	10	IV High Speed Operation .....	18
C.5 Operating Speeds .....	11	V Oil Mist Lubrication For High Speed MCRT® Products .....	18
C.6 High Speed Operation .....	11	VI Hazardous Environments .....	19
C.7 Lubrication .....	11	VII Belt/Chain Drive Considerations .....	20
C.7.1 Standard DC Operated Torquemeters .....	11	VIII Calibration and Compliance Certification .....	20
C.7.2 Oil Mist For High Speed Products .....	11		
C.8 Contaminants .....	11		
C.9 Hazardous Environments .....	12		

# MCRT® 79000V SERIES TORQUEMETER INSTALLATION AND OPERATION GUIDE

## i. Introduction

When installed between a driver and load, MCRT® DC Operated Torquemeters measure static and dynamic shaft torque. Torque sensing employs field proven, strain gage technology. A corrosion resistant, one piece shaft is gaged with one or more bridges. The bridge measures torque and cancels signals from bending and thrust loads. Careful temperature compensation eliminates zero, span and calibration drift.

*Rotary transformers* connect the rotating gages to stationary,  $\pm 5$  volt output circuitry. They provide high quality non-contact signal coupling between rotor and stator. Rotary transformers don't generate noise or wear. They are immune to ambient noise, vibration, lubricants and other hostile environments.

Torque meter circuitry is shielded from RFI which fact, combined with the absence of low level cables, yields extraordinary noise immunity, even close to large electric machines. Elimination of slip rings, brushes, radio transmitters and other limited-life, noise-generating elements further increases performance and reliability. Moreover, the *non-ferrite design* makes these torque-meters suitable for diesel and other hostile applications.

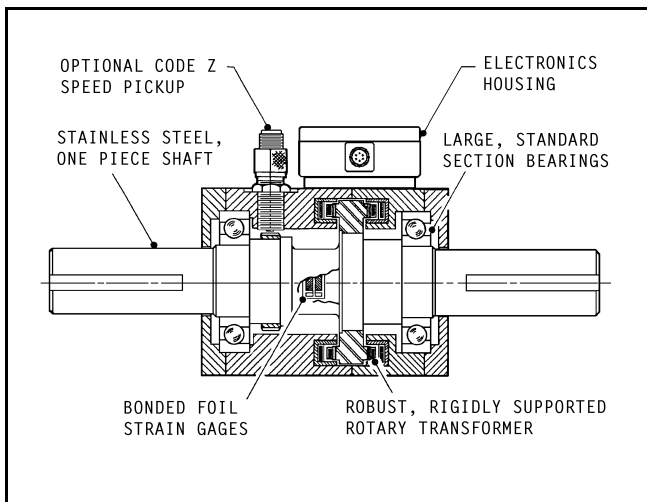

Figure 1. DC Operated Torquemeter Construction

## ii. MCRT® DC Operated Torquemeter Specification

The tabulation lists condensed specifications applicable to standard MCRT®79000V torque meters. Options K and L modify performance. See Bulletin 7700 for complete details.

### MCRT®79000V Series Condensed Specifications\*

	Performance	
	Low Range	High Range
<b>Non-linearity**</b> (% of Range) . . .	$\pm 0.10$	$\pm 0.07$
<b>Hysteresis</b> (% of Range) . . . . .	$\pm 0.10$	$\pm 0.07$
<b>Non-repeatability</b> (% of Range) . . . . .	$\pm 0.05$	$\pm 0.03$
<b>Combined Error</b> (% of Range) . . . . .	$\pm 0.15$	$\pm 0.12$
<b>Temperature Effects</b>		
Zero (% of Range/deg. F.) . . . . .	$\pm 0.0025$	$\pm 0.001$
Span (% of Rdg./deg. F.) . . . . .	$\pm 0.0025$	$\pm 0.001$
Compensated Range (deg. F.) . . . . .	+75 to +175	
Maximum Usable Range (deg. F.) . . . . .	- 25 to +185	
Storage Range (deg. F.) . . . . .	- 65 to +225	
<b>F.S. Output</b> (Dual outputs for each range, as follows)		
Clockwise (CW) Torque . . . . .	+5 V, +10V Option L	
Counterclockwise (CCW) Torque . . . . .	-5 V, -10V Option L	
Minimum Resistive Load . . . . .	10 k $\Omega$	
Maximum Capacity Load . . . . .	0.05 $\mu$ F	
<b>Electrical Overrange</b> (% of Range) . . . . .	$\pm 33$	
<b>Bandwidth</b> . . . . .	High Freq. Output: dc to 500 Hz, dc to 1,100 Hz with Option K, and Low Freq. Output: dc to 1 Hz.	
<b>Zero Control Range</b> (% of Range) . . . . .	$\pm 5$	
<b>Span Control Range</b> (% of Range) . . . . .	$\pm 5$	
<b>Supply Voltage</b> . . . . .	10.5 to 24 Volts dc, except 18 to 24 Volts for Option L	
<b>Supply Current</b> . . . . .	100 mA, nominal	

\* Subject to change without notice.  
 \*\* End point method.  
 Rdg. denotes "reading".  
 deg. F denotes "degree Fahrenheit".

## A. Mechanical Installation

### A.1 Applicability

This discussion is applicable to both MCRT® shaft, and flanged torque meters.

## A.2 Coupling Selection

Your torque meter installation method dictates the type of coupling needed. There are two installation methods, i.e., a *floating shaft* and a *foot mount*.

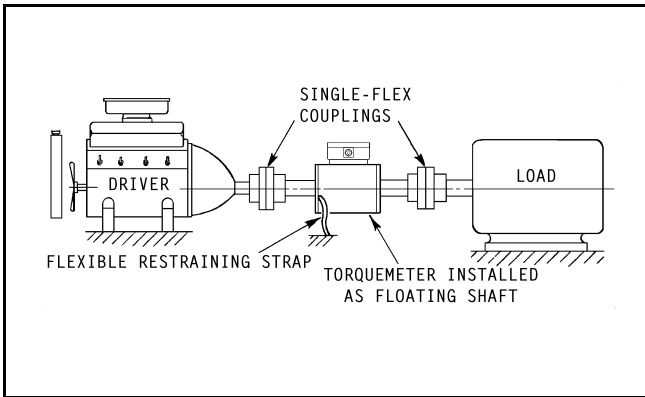

Figure 2. Floating Shaft Installation

Floating shaft installations are applicable to both shaft and flanged type torque meters. A *single flex coupling* is installed at each shaft end. It takes out angular misalignment, and the torque meter "tilts" to take out parallel misalignment. Use a *flexible strap* to prevent housing rotation and to strain relieve the torque meter electrical cable.

**Caution:** If electrical connections are run in a short, rigid conduit, you must foot mount the torque meter. Alternately, use flexible conduit and single flex couplings.

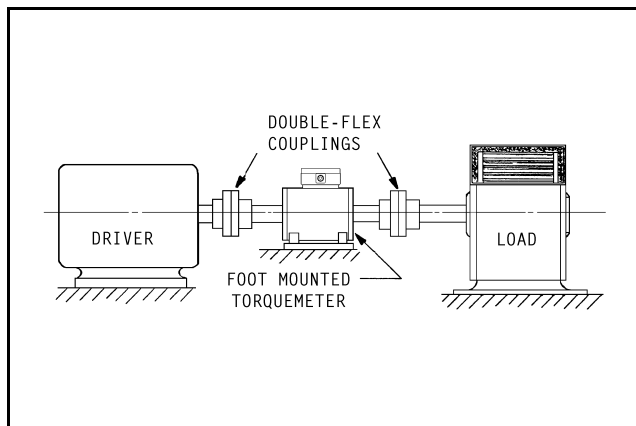

Figure 3. Foot Mounted Installation

Install a foot mounted Torquemeter between *double flex couplings* as shown. The double flex couplings accommodate both parallel and angular misalignments.

Appendix I discusses the choice of a foot mounted or a floating shaft installation. It also contains additional comments on coupling selection. For either installation method, choose couplings that will handle the:

- expected shaft end float
- parallel and angular misalignments
- maximum expected shaft speed
- maximum expected shaft torque
- expected extraneous loading

## A.3 Coupling Installation

Use a slight interference fit (0.0005 inches per inch of shaft diameter) and follow the coupling manufacturers' instructions. Before installation, lightly coat the torque meter shaft with an anti-seizing compound suitable for use at 400 deg. F. Next, heat the coupling hub, **not the torque meter**, to approximately 400 deg. F. Then, install the coupling.

The heated coupling hub should "slip" on the torque meter shaft without significant resistance. That is, coupling installation force shouldn't exceed 10% of the axial load tabulated in ¶C.3. Next, allow the assembly to cool to room temperature. Then, repeat the process for the second coupling.

If desired, use forced air to accelerate cooling. Air cooling avoids contaminating the DC Operated Torquemeter with anti-seizing compound. If cooling is speeded with water dampened rags, **orient the torque meter to prevent entry of water mixed with anti-seizing compound**. Otherwise, internal damage can occur.

After coupling installation, verify that

- clearance exists between the coupling and the torque meter stator, and
- the shaft-to-coupling fit is snug enough to prevent vibration induced coupling motion.

## MCRT® 79000V SERIES TORQUEMETER INSTALLATION AND OPERATION GUIDE

### To Avoid Damage Or Injury

- Use fixturing to support the hot shaft.
- Use insulated gloves when handling hot parts.
- Stop the hub installation if the pressing force exceeds a few pounds. Remove the coupling. Cool all parts, and then inspect for burrs on the coupling bore, shaft, keys and keyways. If the parts are burr free, check the bore size and verify the coupling keyway squareness.
- Don't allow fluids to enter the torquemeter.

### A.4 End-to-End Orientation

#### A.4.1 Effect on Signal Polarity

MCRT® torquemeters are bi-directional. Their output signal polarity reverses when the direction of transmitted torque reverses. Himmelstein uses the following convention for defining torque direction.

- CW Torque:* the shaft turns CW, when viewed from the driven end
- CCW Torque:* the shaft turns CCW, when viewed from the driven end

Reversing a torquemeter end-for-end doesn't change the torque direction or magnitude. Therefore, it will have no effect on the torquemeter output signal. When in doubt about shaft torque direction, observe the output signals during normal machine operation. A positive signal output indicates CW torque per the above definition. A negative output signal signifies a CCW torque.

*Torque signal polarity is fixed at the factory and is not field changeable.*

#### A.4.2 Effect on Torquemeter Thrust Capacity

Orienting a **foot mounted** torquemeter per Figure 4 will provide increased uni-directional thrust capacity. Because dynamic thrust loading is usually bi-directional, it's safest to limit bearing axial (thrust) loads per ¶C.3. **Orientation does not affect the thrust capacity of torquemeters installed as floating shafts.**

When axial bearing loads are *uni-directional*, the orientation illustrated in Figure 4 increases the uni-directional thrust rating by a factor of four (4). Remember, the *increased uni-directional rating applies only to optimum orientation of foot mounted torquemeters.*

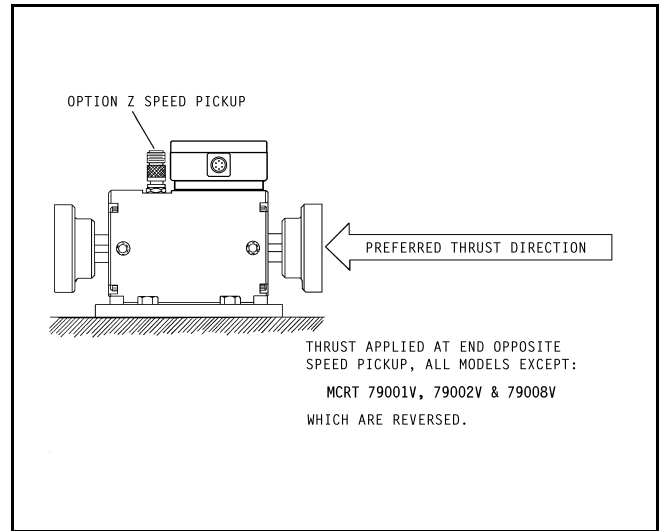

Figure 4. Preferred Thrust Path

### A.5 Vertical Installations & Belt/Chain Drives

Vertical installations frequently require special mounting and coupling selection considerations. See Appendix II for vertical installations and Appendix VII for belt/chain drives.

## B. Electrical Installation

### B.1 Applicability

This section is applicable to all MCRT® DC Operated Torquemeters.

### B.2 Torque Signal

#### B.2.1 Electrical Connections

Connect excitation power to connector pins A and B; see Figure 5. Reverse polarity protection is standard. Observe the load resistance and capacity limits specified. **The torquemeter case should be connected directly to earth ground when conduit isn't used or, if its not reliably grounded.** Although any wire may be used for connections, *shielded cable will perform best in noisy environments and is recommended.* Note: The mating connector with cable clamp and boot, part number 320-1255, is furnished.

**Caution: Don't connect a DC Operated Torquemeter to a power supply that also drives inductors or solenoids. Induced switching transients may cause damage or blow fuses. Use a Linear rather than a Switching power supply. Some switching supplies can cause noise issues.**

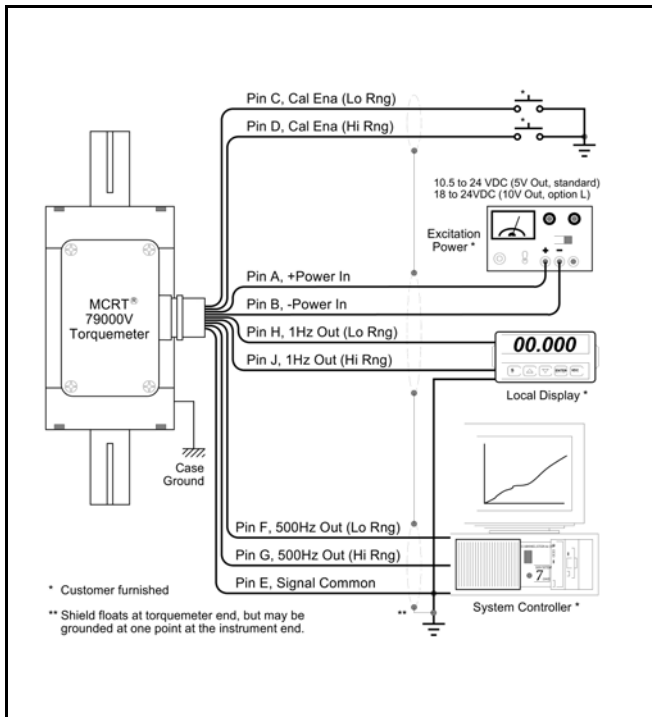

Figure 5. MCRT® 79000V Electrical Connections

### B.2.2 Output Bandwidth Selection

MCRT® 79000V Torquemeters have 4 outputs; a 1 Hz and a 500 Hz output for each range.

The Low Range 1 Hz Output appears at connector pin H; the High Range 1 Hz output is on Pin J. **Pin E is signal common.** The 1 Hz cutoff is useful for eliminating vibratory signals, when present. These outputs are also used when the *average torque*, rather than the *instantaneous torque*, is desired.

The Low Range 500 Hz Output appears on pin F; the High Range 500 Hz output is on Pin G. Option K increases the 500 Hz cutoff to 1,100 Hz. These outputs are preferred as input to fast torque controllers and for driving high speed data acquisition systems.

To enable Low Range Cal, short Pin C to Pin E. To enable High Range Cal, short Pin D to Pin E. You cannot invoke High and Low Range Cal Signals simultaneously.

Spare connectors can be ordered from the factory; P/N 320-1255. Interconnect cables for Himmelstein instruments are also available; call the factory.

Each torquemeter is factory calibrated on *dead weight stands traceable to NIST*. CW and CCW equivalent calibration torques are referenced to that dead weight calibration. That calibration data and a compliance certification are appended to this document.

### B.2.3 Zero and Span Adjustment

**These adjustments must be made with zero torque on the driveline.** To achieve zero torque in installations that can "lock-in" friction torques (between gear drives, on pump and other sealed shafts, etc.), break or disconnect one of the shaft couplings.

1. Unscrew and remove the electronic housing cover.
2. *While monitoring the desired output (see above),* adjust the **low range zero control** for zero torque output, i.e., 0 volts.
3. **Activate** and **hold** the **low range cal enable**, then adjust its' **span control** for the calibration torque voltage listed on the attached calibration printout.
4. Release the **cal enable**, then verify the output is 0 volts. Re-adjust the **zero control**, if necessary. Then repeat steps 2 and 3 until the zero torque output is 0 volts, and the calibration torque output matches the value listed on the calibration printout.
5. Repeat steps 2 thru 4 for the **high torque range** using the **high range controls**.
6. Replace the electronic housing cover.

The torquemeter is now referenced to the factory NIST traceable Dead Weight Calibration. Its output will be 5 volts when full scale torque is applied. For other torques, the output will vary linearly with torque; i.e., at half scale it will be 2.5 volts, at 20% of scale it will be 1 volt, at zero torque it will be 0 volts, etc.

### B.2.4 Calibration Intervals

*For continuous service usage, make monthly calibration and zero checks per ¶B.2.3, above.* When used intermittently, perform those checks before each test series.

In applications requiring high accuracy, perform an annual torquemeter *dead weight calibration*. If the DC Operated Torquemeter is overloaded or operates abnormally, then calibrate/inspect it at once.

Himmelstein offers accredited, dead weight calibration service, traceable to NIST, for all its products. If you purchased a torquemeter with readout, return both with interconnect cables for a *system calibration*. A system calibration will provide the highest measurement accuracy as well as assurance that all system components are functioning properly.

# MCRT® 79000V SERIES TORQUEMETER INSTALLATION AND OPERATION GUIDE

## B.3 Speed Signal

Both *passive (Code A)* and *zero velocity speed pickups (Code Z)* are options for MCRT® DC Operated Torquemeters. A speed pickup *Code N* is used when the speed pickup is omitted. Both pickup types produce exactly 60 pulses per shaft revolution\*. Hence, their output frequency in hertz equals the shaft speed in rpm.

\* Low capacity MCRT® 48000V and 49000V torquemeters are an exception. They use a 512 pulse/revolution, zero velocity, optical encoder for a speed pickup. Refer to applicable specifications for details.

A *passive speed (Code A) pickup* requires no external power. Its output voltage is approximately proportional to speed. Thus, below 100 rpm, a *Code A passive pickups' output voltage* may be too small to be useful. However, the *output voltage* of a *Code Z zero velocity pickup* is independent of speed. Therefore, they are the choice for low speed measurements. *Zero velocity pickups* are also preferred in noisy electrical environments, i.e., where SCR and Triac Motor Controllers and similar devices are present.

### B.3.1 Code A Passive Speed Pickup Connections

Pin	Function
A	Signal
B	Signal

**Note:** Signal wires are isolated from the connector shell.

**Mating Connector:** MS-3106A-10SL-4S  
(SHC P/N 224-3897; includes cable clamp and boot assembly)

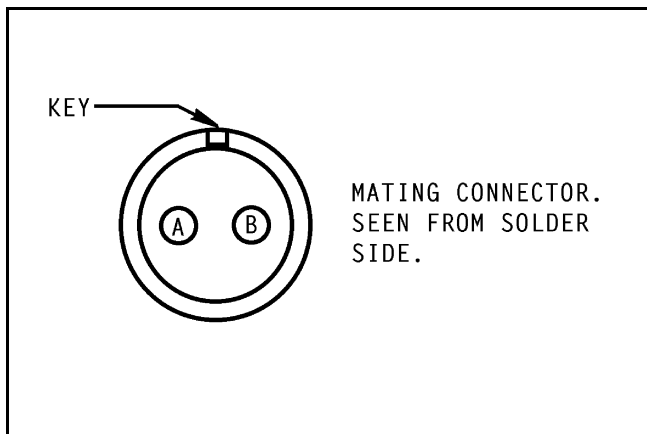

Figure 6. Code A Speed Pickup Connector

### B.3.2 Code A Passive Speed Pickup Cabling

Refer to the manufacturers' manual for speed signal conditioner/readout connections. Use a stranded and shielded twisted pair wire. Belden Type 8761 (or equal) is recommended.

**Cable Diagram for Himmelstein Speed Signal Conditioners** - Figure 7 shows connections for Himmelstein Models CTUA, 702, 722, 721, 723, 723-B, 726, 728 and other compatible Series 700 Instruments. When using another readout, substitute its plug designations for those shown.

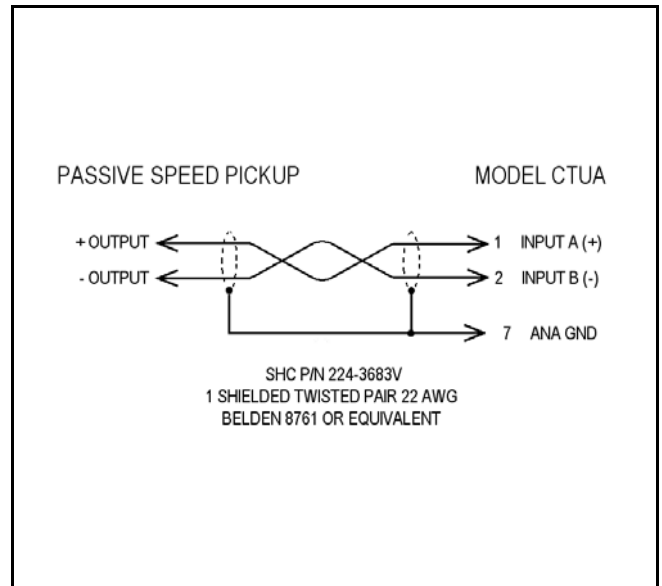

Figure 7. Code A Passive Speed Pickup Cable

### B.3.3 Code Z Speed Pickup Pinout

Pin	Function
A	+ Supply (5 to 15 Volts DC)
B	Output Signal
C	Common

**Notes:** All pins are isolated from the connector shell. Incorrect connections can damage the pickup.

**Mating Connector:** MS 3106A-10SL-3S  
(SHC P/N 224-5361; includes cable clamp and boot)

### B.3.4 Zero Velocity Speed Pickup Cabling

Refer to the manufacturers' manual for speed signal conditioner/readout connections. Use stranded and shielded three conductor cable. Belden Type 8723 (or equal) is recommended.

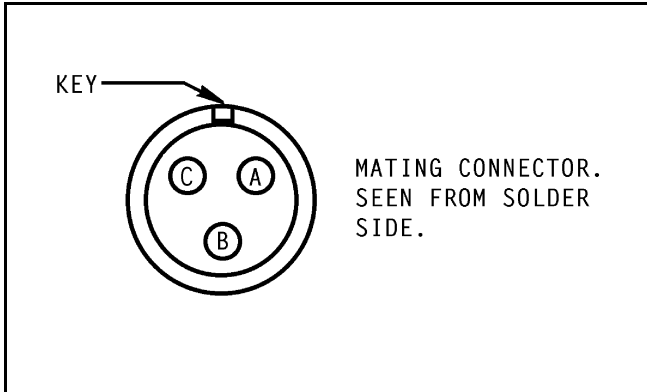

Figure 8. Code Z Speed Pickup Connector

### Cable Diagram for SHC Speed Signal Conditioners

Figure 9 connections are for for Himmelstein Models CTUA, 702, 722, 721, 723, 723-B, 726, 728 and other compatible Series 700 Instruments.

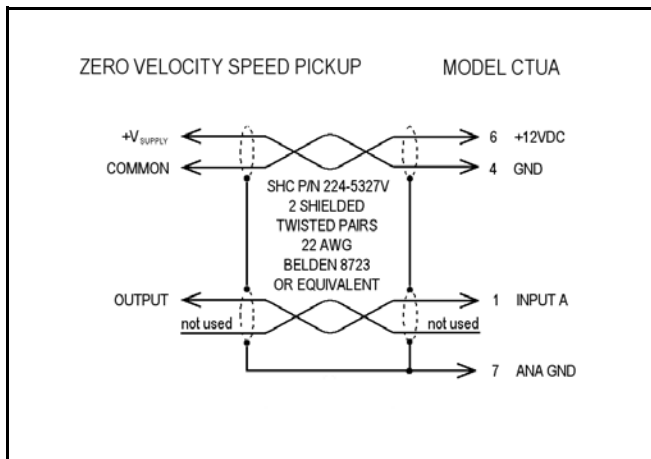

Figure 9. Code Z Speed Pickup Cable

## C. Operating & Safety Considerations

### C.1 Applicability

The following paragraphs apply to all MCRT® products.

### C.2 Allowable Torque Loads

Operate an MCRT® torquemeter within its full scale; see booklet cover for rating of this device.

### C.2.1 Overload Considerations

The overload rating of an MCRT® 79000V Series Torquemeter is typically 2 times the high range full scale but, can be lower. This torquemeters' overload rating is listed on the cover sheet. A Himmelstein torquemeter will not yield (evidenced by a non-return to zero) or fail if subjected to an *instantaneous peak torque* up to its overload value.

Both the full scale and overload ratings are based on the peak stress seen by the transducer. They are independent of stress duration except, for cyclical (or fatigue) loading considerations; see ¶C.2.2. Virtually all rotary power producing and absorbing devices produce pulsating rather than smooth torque and power.

Thus, in addition to its average torque and speed values, the driveline torque usually includes a fundamental (driving) frequency and superimposed harmonics. Torsional vibration magnitudes can be amplified by the driveline. See ¶E.4 for further information. The Figure 10 waveform is typical of what occurs in the real world.

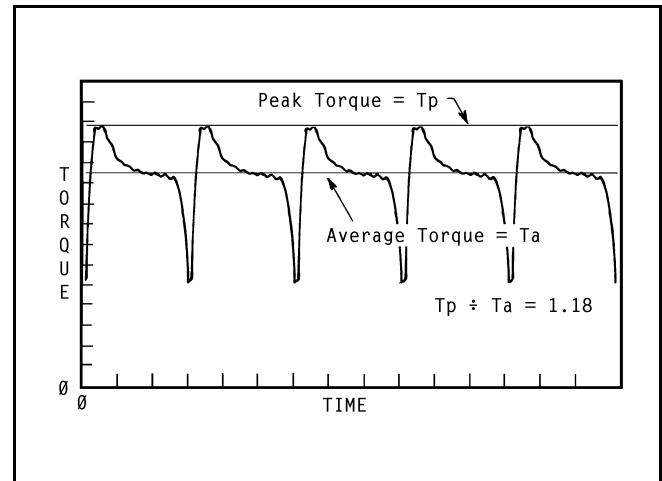

Figure 10. Reciprocating Machine Torque Profile

For these reasons, a conservative design approach dictates the ***torquemeters' overload => twice the probable peak torque. Reserve the region between the peak instantaneous torque and the torquemeters' overload rating as a safety margin for unexpected loads. Do not knowingly operate in the overload region.*** If you expect torques in the overload region, then change to a torquemeter with a higher overload rating.



## MCRT<sup>®</sup> 79000V SERIES TORQUEMETER INSTALLATION AND OPERATION GUIDE

### C.2.2 Fatigue Considerations

If the peak torque seen by an MCRT<sup>®</sup> Torquemeter is less than half its overload rating, it can handle full torque reversals with infinite fatigue life. When peak torques are cyclical, and exceed 50% of the overload rating, then fatigue failure can occur. Refer to Appendix III for additional details.

### C.2.3 Starting High Inertias with Electric Motors

When started across the line, *during the start*, a motor's developed torque can be several times its rated torque. Thus, a DC Operated Torquemeter sized to handle the motor's rated load torque, can be overloaded during starting. Drivelines are particularly vulnerable when oversized motors drive light duty, high inertia loads.

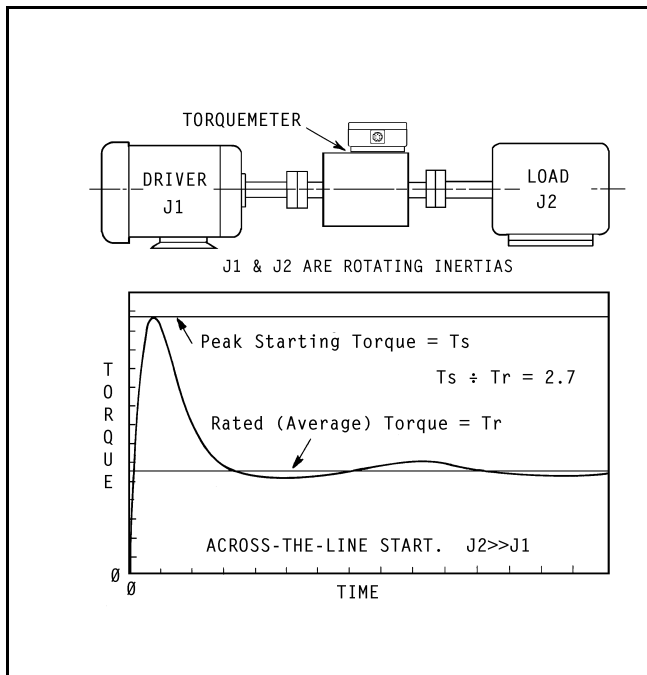

Figure 11. Motor Start Torque Profile

To avoid damage when starting high inertia loads, use a torquemeter *rated for the starting torque or, limit the starting torque to a safe value.* Techniques to limit electric motor starting torques include:

- Use reduced voltage starting.
- Electronically limit the maximum motor current.
- Add inertia to the input side of the torquemeter.

Before operating, verify the motor can safely start the increased load inertia.

- Use "shock absorbing" couplings. Careful coupling selection and thorough analysis is essential. Under some conditions, such couplings can aggravate rather than improve the situation.

### C.3 Allowable Bearing Loads

MCRT<sup>®</sup> Torquemeter bearing design provides long life, smooth running, and avoids bearing torque measurement errors. These results are achieved, in part, by providing optimum bearing pre-load. A lower pre-load would degrade high speed performance. A higher pre-load would increase bearing friction torque, increase measurement error, and reduce bearing life.

In a floating shaft installation, the stator must be **flexibly restrained** so total loads, including the stator restraint and shaft runout, don't exceed its bearing rating. A *stranded wire or braided cable* will provide this flexible restraint and strain relieve the electric cable.

When the stator is foot mounted, the coupling **end float must be sufficient to take up axial shaft motions and hold the bearing loads within the limits specified in the following table.**

When using shaft and flanged torquemeters in belt/chain drives, pillow blocks are usually needed to isolate them from radial bearing and bending loads (see ¶C.4). Consider pulley or wheel type torque sensors for such service. Their bearings are isolated from the belt loads, and they accept large radial and bending loads without damage or measurement errors.

Shaft Type	Bi-directional** Bearing Load	
	Axial (lbs)	Radial (lbs)
<b>DC Operated Torquemeters</b>		
MCRT <sup>®</sup> 79001V	15	35
MCRT <sup>®</sup> 79002V	30	80
MCRT <sup>®</sup> 79003V	35	100
MCRT <sup>®</sup> 79004V	35	110
MCRT <sup>®</sup> 79006V	55	150
MCRT <sup>®</sup> 79007V	70	200
MCRT <sup>®</sup> 79008V	80	220
MCRT <sup>®</sup> 79009V	300	1,000
MCRT <sup>®</sup> 79010V	1,000	3,000

\*\* See ¶A.4.2 for increased axial load ratings.

Flange Type DC Operated Torquemeters	Bi-directional Bearing Load	
	Axial (lbs)	Radial (lbs)
MCRT® 79060V	25	75
MCRT® 79061V	25	75
MCRT® 79070V	50	150
MCRT® 79080V	80	220
MCRT® 79090V	300	1,000
MCRT® 79091V	1,000	3,000

*Flanged models must be mounted as floating shafts.* If they are used without flexible couplings, alignment must limit bearing loads to indicated values. Observe bending and thrust limits specified in ¶C.4.

#### C.4 Allowable Extraneous Loads

Any moment or force the DC Operated Torquemeter sees, other than the transmitted torque, is an extraneous load. Depending on the installation, these could include bending moments and axial thrust. Crosstalk errors from such loads, expressed in pound-inches, are typically 1% of the applied pound-inches of bending or, 1% of the applied pounds of thrust.

##### C.4.1 Allowable Bending Loads

When it is applied without thrust, a standard MCRT® DC Operated Torquemeter, *mounted as a floating shaft*, can handle a shaft bending moment equal to one half its torque rating. Such bending may be applied simultaneously with rated torque.

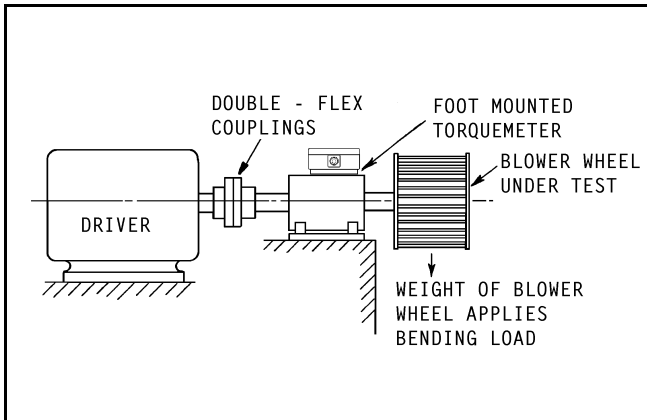

Figure 12. Torquemeter With Bending Load

The allowable bending input to a foot mounted torque-meter (Figure 12) is dictated by its bearing radial load

ratings (see ¶C.3), and by the need to prevent coupling "lock-up". When a coupling locks-up, it no longer provides one or more needed degrees of freedom and, *ultimately causes a driveline failure.*

#### Caution

*Use pillow blocks to isolate a foot mounted torquemeter from excessive bending and radial loads. When applying such loads, don't exceed a torquemeters' bearing load ratings; see Appendix VII for explicit details.*

##### C.4.2 Allowable Thrust Loads

When applied without bending, most MCRT® Torquemeters, *when mounted as a floating shaft*, can handle a thrust load (tension or compression) in pounds, applied to its shaft (see Figure 13), equal to its torque rating in pound-inches. Some units may have different thrust capacities; refer to the applicable Specification or Descriptive Bulletin. Such thrust may be applied simultaneously with rated torque.

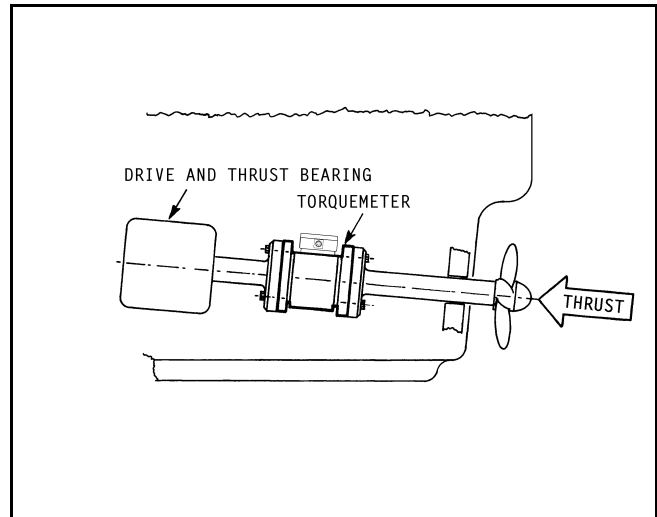

Figure 13. Torquemeter With Thrust Load

#### Caution

*Large thrust loads are only allowable in floating shaft installations. Bearing axial loads limit the thrust capacity of foot mounted torquemeters; see ¶C.3 and ¶A.5.*

## MCRT® 79000V SERIES TORQUEMETER INSTALLATION AND OPERATION GUIDE

### C.5 Operating Speeds

**Operate MCRT® DC Operated Torquemeters within the maximum speed rating published in the pertinent specification and appearing on the cover of this booklet.** The ratings are bi-directional. Standard torquemeters do not require external lubrication.

#### **Caution**

***If a driveline part fails, dynamic balance is lost and the resultant forces can cause other part failures. Therefore, it is an essential safety requirement that guard covers, substantial enough to contain any separated mass, be installed.***

### C.6 High Speed Operation

Refer to Appendix IV for information on high speed torquemeter operation.

### C.7 Lubrication

#### C.7.1 Standard MCRT® DC Operated Torquemeters

The following data applies to all MCRT® Torquemeters except oil-mist lubricated high speed units. Standard torquemeters are permanently lubricated. Nonetheless, they should be re-lubricated every six months. Nye Lubricants, Inc. rust inhibited Synthetic Oil 181RA (or equal) is recommended. Salient characteristics of 181RA oil are:

Service Range (°C)	-40 to 125
Viscosity (cSt @ 100 °C)	9.5
(cSt @ 40 °C)	60.7
(cSt @ -40 °C)	25,300
Viscosity Index (ASTM D-2270)	131
Pour Point (°C)	-56
Flash Point (°C)	240
6.5 Hour Evaporation @ 204 °C	3.7%
Neutralization # (mg KOH/g; ASTM D-974)	0.01

To re-lubricate, remove the threaded closures at either end of the MCRT® device; See Figure 14. Add lubricant per the table, then close the ports.

#### **Caution**

***Do not over lubricate. Too much lubricant will cause viscous losses and excessive heating at high speeds.***

	<b>Permanent Lubrication Limit*</b>	<b>Lubrication Per Bearing</b>
MCRT® 79001V	15,000 RPM	10 drops
MCRT® 79002V	15,000 RPM	13 drops
MCRT® 79003V	10,000 RPM	16 drops
MCRT® 79004V	10,000 RPM	16 drops
MCRT® 79006V	8,000 RPM	4 cc
MCRT® 79007V	6,000 RPM	5 cc
MCRT® 79008V	3,600 RPM	7 cc
MCRT® 79009V	1,800 RPM	13 cc
MCRT® 79010V	1,200 RPM	26 cc
MCRT® 79060V	8,000 RPM	8 drops
MCRT® 79061V	8,000 RPM	8 drops
MCRT® 79070V	5,500 RPM	20 drops
MCRT® 79080V	3,600 RPM	7 cc
MCRT® 79090V	1,800 RPM	13 cc
MCRT® 79091V	1,200 RPM	26 cc

\*For maximum life, re-lubricate on a six month schedule.

#### C.7.2 Oil Mist For High Speed MCRT® Products

Special order, suffix "H" high speed devices must be oil mist lubricated. Refer to Appendix V for instructions.

### C.8 Contaminants

Don't **flood** a torquemeter with liquids. At high operating speeds, excessive viscous losses will occur and can cause heating that could damage the torquemeter.

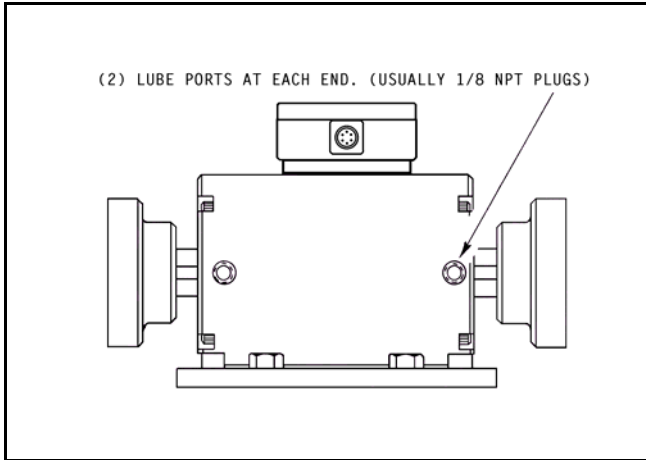

Figure 14. Torquemeter Lube Ports

MCRT<sup>®</sup> devices are immune to spray from mineral based oils and natural, hydrocarbon hydraulic fluids. When using synthetic fluids, verify they are compatible with plastic and electrical insulation. Protect the torquemeter from contact with fluids that attack insulation or plastics. Warranties are void for damage caused by such materials.

Airborne abrasive can cause premature bearing failure. When they are present, consider using an air purge to prevent invasion of such materials. See Appendix VI for additional information on air purging.

### C.9 Hazardous Environments

Refer to Appendix VI when operating in hazardous environments.

## D. Troubleshooting

### D.1 Scope

These discussions suggest procedures for identifying a defective system component. They are an aid for operating personnel. Special training and adequate inspection, test and assembly fixtures are needed for extensive repair work.

Possible trouble sources include the installation, the DC Operated Torquemeter, the cabling and the readout device. The best procedure is to isolate the problem part, then correct or replace it. Otherwise return the defective part to the factory.

## D.2 Preliminary Inspection

### D.2.1 DC Operated Torquemeter

Inspect the torquemeter for physical damage. If the shaft is locked or a rub exists, remove the speed pickup, if present, per instructions contained in ¶D.4.4. If the fault clears, reinstall the pickup following ¶D.4.4 instructions. Otherwise return the unit to the factory.

### D.2.2 Cabling

Make electrical checks for continuity and shorts; see Paragraphs B.2 and B.3 for connections. **Verify that the torque connections are tight and they are made per Figure 5.** Erratic connections and the omission of shielding can produce signal noise. If signal noise is a problem, then replace the torque cable with one that is shielded. Similarly, replace unshielded speed cables with cable configured per ¶B.3. Examine the torque and, where present, speed cables for obvious damage. Replace damaged cables. Clean connectors with an approved contact cleaner.

### D.2.3 Readout Instrument

Examine for physical damage, blown fuses and/or loose parts. Correct any defects; refer to the manufacturers' manual, as necessary.

## D.3 Torque Subsystem Problems

### D.3.1 No Output When Torque is Present

Check the torquemeter circuitry for a blown fuse and replace it if necessary. The fuse is located on the upper circuit board and must be soldered in place. Verify that power is present, its polarity is correct, and the cable is intact, i.e., excitation voltage appears at the torquemeter terminals and that it is between 10.5 and 24 volts dc for standard units or, between 18 and 24 volts dc for Option L units. Finally, verify the load is within the specified maximums. If all checks are negative, the problem is in the torquemeter. Return it for factory service.

### D.3.2 Constant Output Regardless of Shaft Torque

If the cable is checked per ¶D.3.1 above and found normal, then the problem is the torquemeter. Return it for factory service.

### D.3.3 Apparent Zero Drift

- **Check the Cabling.** See ¶D.2.2.
- **Check for a Drifting Amplifier/Receiver.** Without changing its span control setting, re-connect it to a known good DC Operated Torquemeter or similar,  $\pm 5$  volt output sensor. If the drift remains, the torquemeter is ok. Clean the input connections with an approved cleaner. If that does not clear the problem, the readout device is drifting. Analyze and correct it or, return it to the manufacturer for service.
- **Check for Driveline Torque Offsets.** Torquemeters installed in a drive which has hysteresis or friction torques, may *appear* to have long term drift when there is none. For example, when installed between a pump and a gear drive, the torque reading may not return to zero after a test because of locked in friction torque. The torquemeter sees and reads that locked in torque. Always zero the torquemeter with no torque on the driveline – in the case cited, with a coupling disassembled. At the end of the test, the shaft should be mechanically "shaken" or a coupling broken, to return the driveline torque to zero. Otherwise, the torquemeter will read locked in torque. A rub between any rotating and stationary part is a common cause of friction. Verify the shaft couplings and other rotating parts have clearance to the stator.

### D.3.4 Signal Instability

- **Check for Amplifier/Receiver Instability.** Perform a torquemeter substitution per ¶D.3.3. If the amplifier/receiver output is stable, then the problem is in the torquemeter or cabling.
- **Check the Cabling.** See ¶D.2.2 above.
- **Check For Driveline Torque Variations.** The driveline may have a low frequency oscillation which the torquemeter reads (see ¶C.2.1). Use the torquemeters' low frequency output to sup-

press signals above 1 hertz. If the readings steady, then you may wish to identify the physical cause of the shaft torque variation or, remove it with mechanical filtering techniques; see ¶E.4. Oscillographic signal analysis is often helpful under these conditions; however, *use the high frequency signal output* during this analysis. If very large, high inertia machines are used, or large machines are used in a control loop, torque and speed oscillations can be present below 1 hertz. They can be identified with an external (to the torquemeter) low pass filter.

### D.3.5 System Will Not Zero

- **Check the Cabling.** See ¶D.2.2 above.
- **Check the Torquemeter.** Substitute a known working torquemeter for the one in question. If it can be zeroed and operation is normal, then the problem is in the torquemeter. Otherwise the readout/amplifier is at fault. Repair it or return it to the manufacturer.
- **Verify the Torque Input is Zero.** If the torquemeter is installed in a driveline, break or remove one of the couplings. If the system still can't be zeroed, then the problem is either the cable or the torquemeter. Verify cable integrity, configuration and connections and check the DC Operated Torquemeter per ¶D.2.1.

### D.4 Speed Subsystem Problems

Speed measurement problems can originate in several components. They include the speed pickup, the readout instrument, and the interconnect cable. The best procedure is to isolate the defective element and then correct or replace that element.

#### D.4.1 No Signal Output When Shaft is Rotating

- **Verify the Shaft Speed is Within the Measurement Range.** Code A passive speed pickups have a practical lower operating speed range of about 100 rpm, depending on the torquemeter and speed readout models. Run the shaft at a higher speed and verify the problem still exists. Zero velocity pickups will work down to zero speed. However, most Himmelstein speed readouts have a lower operating limit of 5 to 10 rpm.

- **Verify the Speed Pickup Signal is Normal.** Measure peak output voltage at a constant speed. If no output exists, verify the cable is intact; replace defective cables. See ¶D.4.4 for pickup output data. If the signal is too low, then re-adjust the pickup location per ¶D.4.4. Misadjustment can cause marginal output.
- **Verify the Speed Readout is Operational.** Connect a known frequency to the readout input. It should be between 200 and 5,000 Hz, and operate at an input level of 0.1 volts, rms. If no output is present, the readout is defective and must be corrected or replaced. Otherwise the problem is in the cable, or the pickup, or the operating speed is beyond the system measurement range.

#### D.4.2 Erratic Output at Constant Speed

- **Check for Cable Faults.** In addition to the usual checks, make certain the shield is in place and only grounded at the amplifier. Verify there is no connection between either signal and shield.
- **Check the Pickup for a Ground Fault.** There should be no connection between the signal wires and the pickup shell.
- **Check the Speed Readout Operation.** Using the techniques described in ¶D.4.1, verify the amplifier output is stable.
- **Verify Pickup Operation.** Verify the pickup output is both normal and stable while the shaft is rotating at a constant speed above 600 rpm.
- **Verify Your Drive Speed is Stable.** Some drives have significant speed variations caused by control system instability, torsional vibrations, etc. To eliminate this possibility, use another drive source – preferably a direct drive motor running between 600 and 3,000 rpm. Alternately, observe the torque variations on an oscilloscope. If they track the speed variations and both signals are stable with the shaft stationary, then the drive is probably unstable and the instruments are correct.

#### D.4.3 Output When the Shaft is Stationary

- **Check the Cable, Speed Pickup and Speed Readout Operation** per ¶D.4.2 above. If a defect is found, correct it. Otherwise proceed to the next step.
- **Check for High Ambient Electrical Noise.** If the torquemeter is installed adjacent to large electrical machines, or the machinery is powered by Solid State Phase or Frequency Speed Controllers, significant noise interference can be present. Remove power from the machines and controls, or turn power to an adjacent machine on and off. If the readout stabilizes when power is off, use the techniques described below.
  1. **Isolate the instrument from the machine power** by powering it from a separate line transformer.
  2. **Reduce the noise** by providing one cable tray or conduit for the speed instrument cable and a separate tray for the machine power and control cables. If possible, use twisted and shielded wire pairs for the motor control cables.
  3. **Increase the speed signal level** by replacing the Code A passive speed pickup with a Code Z zero velocity pickup (and cable). Then, adjust the speed amplifier to optimize the signal-to-noise ratio. Instructions for optimal adjustment of Himmelstein speed amplifiers can be obtained from the factory.

#### D.4.4 Speed Pickup Adjustment/Replacement

Standard speed pickups are field changeable. They thread into the stator housing and are secured with a jam nut. Loosen the jam nut to remove or adjust the pickup. Both the passive (Code A) and zero velocity (Code Z) types require radial location adjustment. Zero velocity types also require azimuth alignment. These adjustments are described below.

## MCRT® 79000V SERIES TORQUEMETER INSTALLATION AND OPERATION GUIDE

### D.4.4.1 Code A Passive Speed Pickups

The nominal outputs of Code A passive pickups are tabulated below. Use an oscilloscope to measure open circuit voltages, while the shaft rotates at the reference speed. The waveform is a distorted sine wave. Make the adjustment using the following procedure:

- Back out the pickup by turning it counterclockwise. Then re-insert it with one thread engaged.
- With the torque meter shaft rotating at the reference speed, slowly turn the pickup clockwise until the output is within 15% of the tabulated value. ***If a rub occurs, stop! Back off the pickup until the rub clears.***
- Stop the shaft and tighten the jam nut.
- Rotate the shaft by hand to verify no rub exists.
- Finally, verify the output is correct at the reference speed. Re-adjust if necessary.

The adjustments described take time and require test facilities. If neither is available, you may use the following *less satisfactory* procedure.

- ***With shaft motion stopped***, turn the pickup in until it contacts the rotor assembly.
- Back off the pickup a quarter of a turn.
- Tighten the jam nut.
- Slowly rotate the shaft to verify no rub exists. If a rub exists, re-adjust the pickup.

<b>MCRT® Torquemeter Model Number</b>	<b>Open Circuit Output (Volts pk-pk)</b>	<b>Reference Speed (rpm)</b>
79001V	3.0	5,000
79002V	3.0	5,000
79003V	2.0	1,000
79004V	2.0	1,000
79006V	1.5	1,000
79007V	1.5	1,000
79008V	2.0	1,000
79009V	1.5	500
79010V	1.7	500
79060V	2.0	1,000
79061V	2.0	1,000
79070V	2.0	1,000
79080V	2.0	1,000
79090V	1.5	500
79091V	1.7	500

### D.4.4.2 Code Z Zero Velocity Pickup

The output of a Code Z speed pickup swings between approximately + 0.25 Volts and the supply voltage less about 0.25 Volts. When used with a Himmelstein read-out, the pickup output will swing from +0.25 to about +14.75 volts. Certain specialized units have TTL (0 and +5 Volt) outputs. Code Z Optical pickups used on low capacity Torquemeters are an exception; they are not field adjustable. To adjust standard magnetic Code Z pickups, proceed as follows:

- ***With shaft motion stopped***, turn the pickup in until it makes contact with the rotor assembly.
- Back off the pickup a quarter of a turn.
- Tighten the jam nut.
- Slowly rotate the shaft to verify no rub exists. If a rub exists, re-adjust the pickup.

Early model DC Operated Torquemeters used a Code Z pickup that required azimuth adjustment. Call the factory for instructions on adjusting those devices.

### D.4.4.3 Replacement Part Numbers

<b>Torquemeter Type</b>	<b>Code A Passive Pickup</b>	<b>Code Z Zero Velocity Pickup</b>
MCRT® 79001V	900-1001	900-1007
MCRT® 79002V	900-1001	900-1007
MCRT® 79003V	900-1001	900-1007
MCRT® 79004V	900-1001	900-1007
MCRT® 79006V	900-1005	900-1007
MCRT® 79007V	900-1005	900-1007
MCRT® 79008V	900-1001	900-1007
MCRT® 79009V	900-1001	900-1007
MCRT® 79010V	900-1022	900-1023
MCRT® 79060V	900-1001	900-1007
MCRT® 79061V	900-1001	900-1007
MCRT® 79070V	900-1001	900-1007
MCRT® 79080V	900-1001	900-1007
MCRT® 79090V	900-1001	900-1007
MCRT® 79091V	900-1022	900-1023

## E. Summary of References

The following paragraphs summarize references pertinent to torquemeter operation, installation and troubleshooting. Those references are too detailed and technical to be made a part of this document. The referenced material is available from the factory. Some of it may be found in the rear of the torque measurement section of Himmelstein Product Catalogs.

### E.1 Torquemeter Loads and Specifications

The cover sheet of this document contains device explicit specifications for the serial number in use. Any special design modifications are identified. Page 3 contains an abbreviated specification. The Models' Technical Bulletin contains complete specifications, and outline information; please see Bulletin 7400 for further data. Bulletin 700 contains additional guidance for achieving a conservative torquemeter installation.

### E.2 Coupling Selection and Torquemeter Installation

Technical Memorandum 7850 contains useful information on coupling selection, mounting, measurement and operating considerations. It includes sketches of acceptable and unacceptable mounting arrangements. Addendum #1 to Technical Memorandum 7850 lists commercial sources of flexible couplings.

### E.3 High Speed Operation

Technical Memorandum 7551 discusses the critical speed of installed torquemeters. It contains procedures for estimating shaft critical speeds, and related material.

### E.4 Minimizing the Effects of Torsionals

Technical Memorandum 8150 discusses the estimation of torsional resonant frequencies, and describes how to avoid their destructive effects. It includes theoretical as well as practical help on the subject.

### E.5 Selecting the Right Torquemeter

Bulletin 705 provides criteria for properly sizing a torquemeter. In addition to average drive torque and/or power requirements, the effect of the load and driver characteristics are explained. The bulletin provides a simple, easy to follow selection procedure and contains many useful examples.

## Appendix I

### Foot Mounted Versus Floating Shaft Installations

Floating shaft installations have two principal disadvantages. First, if the driving or driven machine is frequently changed, and the torquemeter is unsupported during the changeover, then pillow blocks must be added to handle this situation. Second, the *critical speed* of a foot mounted torquemeter is usually much higher than a floating shaft torquemeter.

If neither of these concerns are important, consider a floating shaft installation. They are less critical to align. Furthermore, because they don't directly transfer thrust and bending loads to the torquemeter bearings, ***floating shaft installations can usually handle much greater thrust and bending loads than the foot mounted alternative.***

Very high speed applications should employ foot mountings; see Appendix IV for additional information.

*For either installation method, choose couplings that will handle the:*

- expected shaft end float
- installation parallel and angular misalignments
- maximum expected shaft speed
- maximum expected shaft torque
- expected extraneous loading

Where dynamic, once per revolution torque measurements are important, *use constant velocity, zero backlash, torsionally rigid couplings.* If operated at high speed, dynamically balance the torquemeter and coupling assembly *after coupling installation.* Install the couplings in accordance with the manufacturers' instructions and ¶A.3.

Technical Memorandum 7850 has detailed installation discussions. Use only installations recommended in that memorandum. If in doubt, consult the factory. Addendum 7850-1 lists commercial coupling types. However, *coupling selection and mounting is the users' responsibility.*



Appendix II

Vertical Installations

In vertical installations, the torque meter and couplings often carry the weight of suspended devices and frequently carry the live thrust of a pump impeller, mixer blade, etc. Even when those dynamic loads are absent, the upper shaft coupling must carry the weight of the torque meter and coupling.

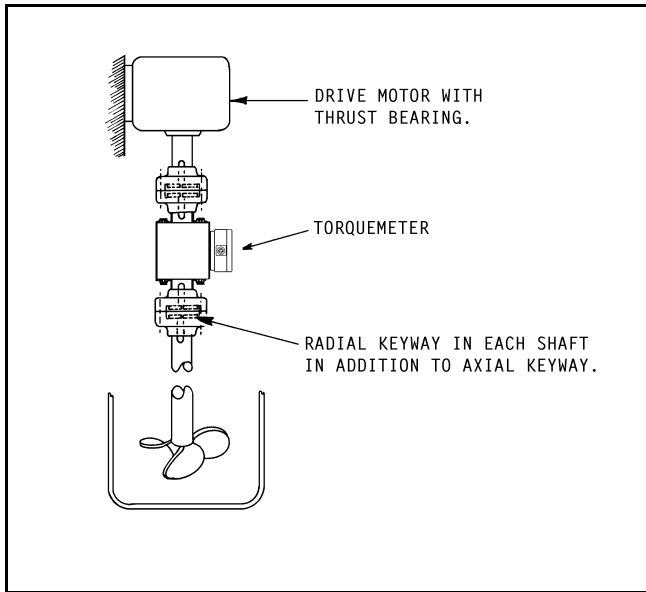

Figure 15. Vertical Torquemeter Installation

A flanged torque meter with properly attached couplings can support substantial thrust loads. It is well suited for vertical drives. On the other hand, neither axial keys nor interference fits will carry significant thrust. Special order shaft torque meters can be supplied with radial keyways to carry thrust loads.

Vertical floating shaft installations don't transfer thrust to the torque meter bearings. Thus, **floating shaft installations are simpler and usually safer than foot mounted installations.** See ¶C.4.2 for data on shaft thrust ratings.

**Vertical, foot mounted installations must limit torque meter bearing loads to those of ¶C.3.**

Appendix III

Fatigue Considerations

MCRT® Torquemeters can handle full torque reversals whose instantaneous magnitude is equal to or less than half the overload rating. Under those conditions, fatigue life is infinite. When peak torques exceed 50% of overload rating, then fatigue failure can occur.

When operated at peak torques above half the overload, fatigue life is a function of several factors. They include the torque magnitude, the magnitude and type of extraneous loads simultaneously applied, the total number of loading cycles, the torque meter configuration, etc.

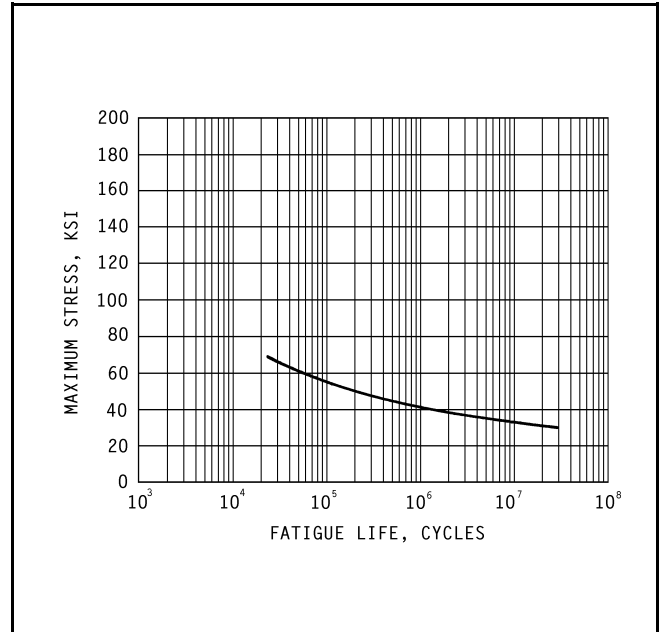

Figure 16. Typical Fatigue Life Characteristics

When large torsionals are present, the following steps will reduce the risk of fatigue failure:

- Reduce the magnitude of torsional inputs by using mechanical filtering (torsional dampers).
- Avoid torque magnification by eliminating torsional resonant frequencies in the operating range; see ¶E.4.
- Size the torque meter so peak instantaneous torques are  $< (\text{overload rating})/2$ .
- Check peak torque values, *over the range of operating conditions*, by observing the torque on an oscilloscope *at the high frequency output*.

If these guidelines are violated, shut down immediately or risk component damage.

## Appendix IV

### High Speed Operation

On special order, Torquemeters can be supplied that operate at higher speeds than their standard counterparts. They are identified by an "H" suffix. The cover sheet of this document lists the speed rating of your torquemeter. "H" suffix devices have strengthened rotor assemblies, revised bearings and provision for oil mist lubrication.

A successful high speed installation requires:

- Adequate bearing lubrication. Too little will result in bearing failure. Too much, produces excessive heating from viscous losses and can cause damage.
- A stable, usually foot mounted, vibration-free installation operating either well below or well above the first shaft system torsional resonant frequency (see ¶E.4). The operating speed should be below the first shaft critical (see ¶E.3).
- A dynamically balanced torquemeter and coupling assembly. All other driveline components must also be balanced.
- Taking all reasonable safety precautions including the installation of safety guards around rotating components.

## Appendix V

### Oil Mist Lubrication For High\* Speed Products

\*H Suffix Devices

**Use oil mist lubrication for special high speed torquemeters.** These products contain structural modifications and oil mist ports that permit operation at high speed. See the cover sheet for the maximum speed rating of the torquemeter supplied. Typically, each end has two 1/8" NPT tapped lubrication ports. Use either port for *Inlet* and the other port for *Drain*. Make the port selection on the basis of installation convenience.

Available options include NPT body fittings, manifolding between bearings, and a lubricator with manifolding. When manifolding is furnished, the torquemeter has a single *Inlet* and a single *Drain*.

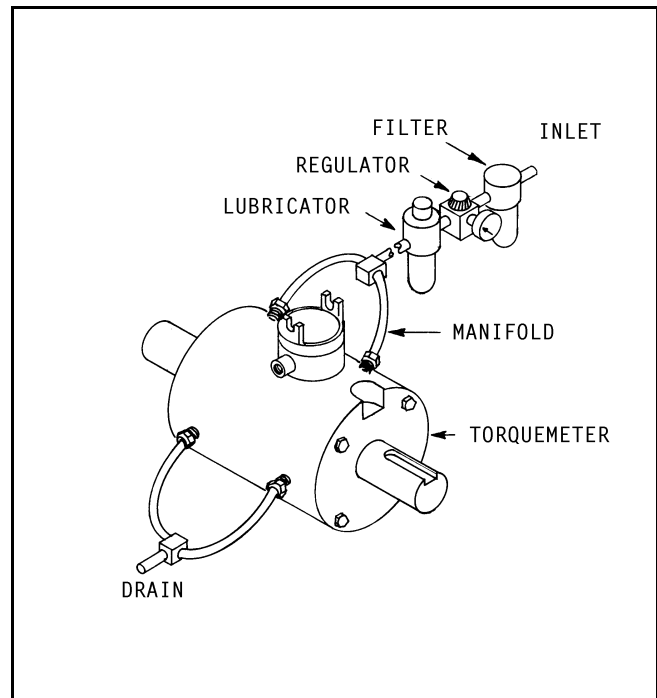

Figure 17. Typical Oil Mist Piping

Certain high speed torquemeters have multiple *Inlet* and *Drain* ports to enhance lubrication. When so furnished, the device manual will include special manifold information.

Before operating an externally lubricated torquemeter, verify the lube path is clear by **confirming oil is recovered from all drains. Loss of lubrication will cause bearing failure. A blocked drain port will trap excess oil, cause overheating from viscous losses, and possible device damage.**

## MCRT® 79000V SERIES TORQUEMETER INSTALLATION AND OPERATION GUIDE

### Recommended Lubricator:

Norgren Lubrication Assembly Consisting Of:

Filter: P/N F11-200-M3PA  
 Regulator: P/N R11-200-RGLA  
 Lubricator: P/N L11-200-MPNA

SHC P/N 944-1006 is a complete assembly including filter, regulator, lubricator and oil reservoir.

### Recommended Lubricant:

MIL-L-6085A. Salient characteristics of this lubricant are:

Viscosity (cSt @ 130 deg. F.)	9.0
(cSt @ -65 deg. F.)	11,740
Flash Point (deg.F.)	455
Pour Point (deg.F.)	-80
Rust/Corrosion Inhibited	Yes
Antiwear Properties	Yes

### Recommended Lubricator Adjustments:

<u>MCRT® Model Number</u>	<u>Oil Rate* (Drops/Min)</u>	<u>Air Flow* (CFM)</u>
79001VH	3	1.5
79002VH	3	1.5
79003VH	4	4
79004VH	4	4
79006VH	5	5
79007VH	6	6
79008VH	6	6
79060VH	4	3
79061VH	4	3
79070VH	5	6
79080VH	6	6

\* Values are total for both device bearings

### Appendix VI

#### Hazardous Environments

When they are used in hazardous locations, **purge MCRT® torquemeters with air (or inert gas)**. Properly used, an air purge will prevent explosive, flammable or corrosive fluid, or airborne abrasive, from entering the torquemeter. **The user must interlock and monitor the purge supply in compliance with safety codes.**

On special order, DC Operated Torquemeters can be modified for air purge operation. Introduce the gas purge through the special purge fitting installed on the electronic housing. Purge air will be ported to the torquemeter interior and will prevent hazardous gases from entering both the torquemeter and electronic housing. **Assuming you feed the connecting wires through approved safety barriers and suitable interlocks are used**, the torquemeter can be operated in a hazardous environment.

A special Code P explosion proof speed pickup should be used in hazardous locations. **Run the speed wires through an approved conduit. If its necessary to use a zero velocity (Code Z) pickup, then make connections via suitable safety barriers.**

Safety barriers are sealed, passive networks installed in each wire that connects the hazardous and safe locations. They limit electrical energy passing between the two locations to a safe value.

#### Special Code P, Explosion Proof Speed Pickup Wiring Color Code

<u>Function</u>	<u>Color</u>
Signal	White
Signal	Red
Case Ground	Green**

\*\*May be omitted on some units

## Appendix VII

### Belt and Chain Drive Considerations

**Caution: Don't install a pulley or sprocket on the torquemeter shaft unless the torquemeters' radial bearing load rating, from ¶C.3, is :**

$$\geq [\text{Torque Rating}] / [4*L]$$

and,

$$\geq [T_1 + T_2] * [1 + L/H]$$

These criteria assure safe torquemeter bending and bearing loads. To simplify your analysis, assume  $T_2 = 0$  and calculate  $T_1 = [\text{Torque Rating} * 2/D]$ . Then, make  $[T_1 + T_2] = 1.1$  times the calculated value of  $T_1$ .

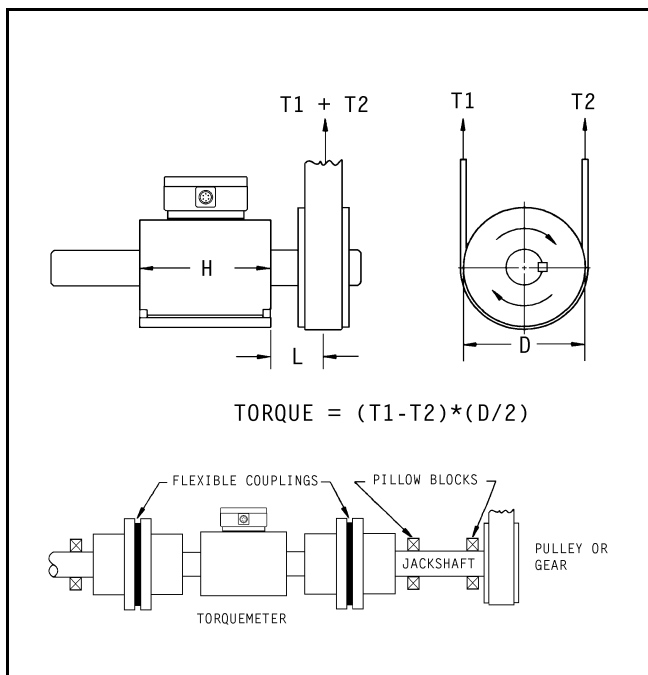

Figure 18. Installation Definitions

When the bearing load ratings don't meet the above criteria, use pillow blocks and a jack shaft to isolate the pulley/belt loads; see Figure 18 example. Alternatively, consider a pulley or wheel type torquemeter. Their bearings are isolated from the belt loads, and they can accept large radial and bending loads without damage or measurement errors.

## Appendix VIII

### WARRANTY STATEMENT AND SPECIMEN CALIBRATION AND COMPLIANCE CERTIFICATION

#### WARRANTY

Himmelstein hereby warrants, to their original purchaser, all its torque measurement products to be free of defects in materials and workmanship and to conform to the published specifications in effect at the time of order. The warranty period begins at the date of original shipment and extends for a period of one year thereafter.

Our liability under this warranty is limited to the obligation to repair or, at Himmelstein's option, replace without charge, F.O.B. our plant in Hoffman Estates, IL, any part found to be defective under normal use and service, provided:

1. The defect occurs within the one year warranty period.
2. Himmelstein is promptly notified in writing upon discovery of such defects.
3. The original parts are returned to Himmelstein, Hoffman Estates, IL, transportation charges prepaid.
4. Himmelsteins' examination shall disclose to its satisfaction that such defects have not been caused by abuse, accident, negligence or misuse after delivery.
5. No unauthorized modification has been made.

Equipment or merchandise not manufactured by Himmelstein is not warranted by Himmelstein but carries its manufacturers' warranty. Our performance warranties are stated in printed specifications for each standard product and in a written description included in system quotations. Himmelstein specifically disclaims any other performance warranties or implied warranties of fitness for a particular purpose. This warranty is expressly in lieu of all other warranties expressed or implied (except as to title) and constitutes all of Himmelsteins' liability in respect to equipment or merchandise sold by it.

#### CALIBRATION AND COMPLIANCE CERTIFICATION (Specimen only. An executed document is attached.)

Himmelstein certifies this torquemeter was thoroughly tested and inspected and meets or exceed its published specifications. The listed calibration values were obtained during this process and are traceable to the NATIONAL INSTITUTE OF STANDARDS AND TECHNOLOGY (NIST).

It further certifies that calibration was performed in its NVLAP accredited (NVLAP Lab Code 200487-0) calibration laboratory. Visit our website or [www.nist.gov](http://www.nist.gov) for a copy of the NVLAP Certificate and the accreditation scope.

**Calibrated by:** ..... **Date:** .....

**Certified by:** ..... **Date:** .....

# S. HIMMELSTEIN AND COMPANY

2490 Pembroke Avenue, Hoffman Estates, Illinois 60169, USA. Tel: 847/843-3300 Fax: 847/843-8488